

MODEL # CIMR-VU	VOLTAGE THREE PHASE (VAC)	OUTPUT CURRENT (A)		WEIGHT LBS (Kg)	HEAT LOSS (W)					
					ND (Fc=2kHz)			HD (Fc=8kHz)		
		ND	HD		INT	EXT	TOT	INT	EXT	TOT
2A0056JXX	208/240	56.0	47.0	10.1 (4.6)	151.8	357.9	509.7	117.6	347.6	465.2
4A0031JXX	380/480	31.0	24.0	9.5 (4.3)	146.1	287.5	433.6	105.9	266.9	372.8
4A0038JXX	380/480	38.0	31.0	10.1 (4.6)	155.8	319.2	475.0	126.6	319.1	445.7

NOTE:
XX DENOTES AA-ZZ

INT=INTERNAL COMPONENTS
EXT=EXTERNAL HEATSINK
TOT=TOTAL

FOR ADDITIONAL DETAILS AND SPECIFICATIONS, CONSULT MANUAL

TOLERANCES / REFERENCES:		<p>YASKAWA The Drive for Quality™</p> <p>THIS DOCUMENT AND INFORMATION CONTAINED IN IT ARE CONFIDENTIAL, AND CANNOT BE COPIED OR DISCLOSED IN WHOLE OR IN PART WITHOUT THE EXPRESS WRITTEN CONSENT OF YASKAWA ELECTRIC AMERICA INC.</p>	DRAWN: J. MATTAS DATE 1-8-09	DATE 1-8-09	TITLE: V1000 DIMENSION DRAWING FRAME SIZE 10 FINLESS HEATSINK 2A0056J, 4A0031J AND 4A0038J	
			CHECKED: J. PIOTROWSKI DATE 4-27-09	DATE 4-27-09		
			TECH: J. CAIRO DATE 7-7-09	DATE 7-7-09		
			APPROVED: T. SASADA DATE 7-8-09	DATE 7-8-09		
UNITS: IN[mm]	SCALE: 1:5	ORIGINAL DESIGN: -	DATE -	SIZE A	REVISION R00	PAGE 1 of 3
				DRAWING #: DD.V1K.FR10.FNL.01		

TERMINAL AND WIRING DETAILS (SCALE 1:3)

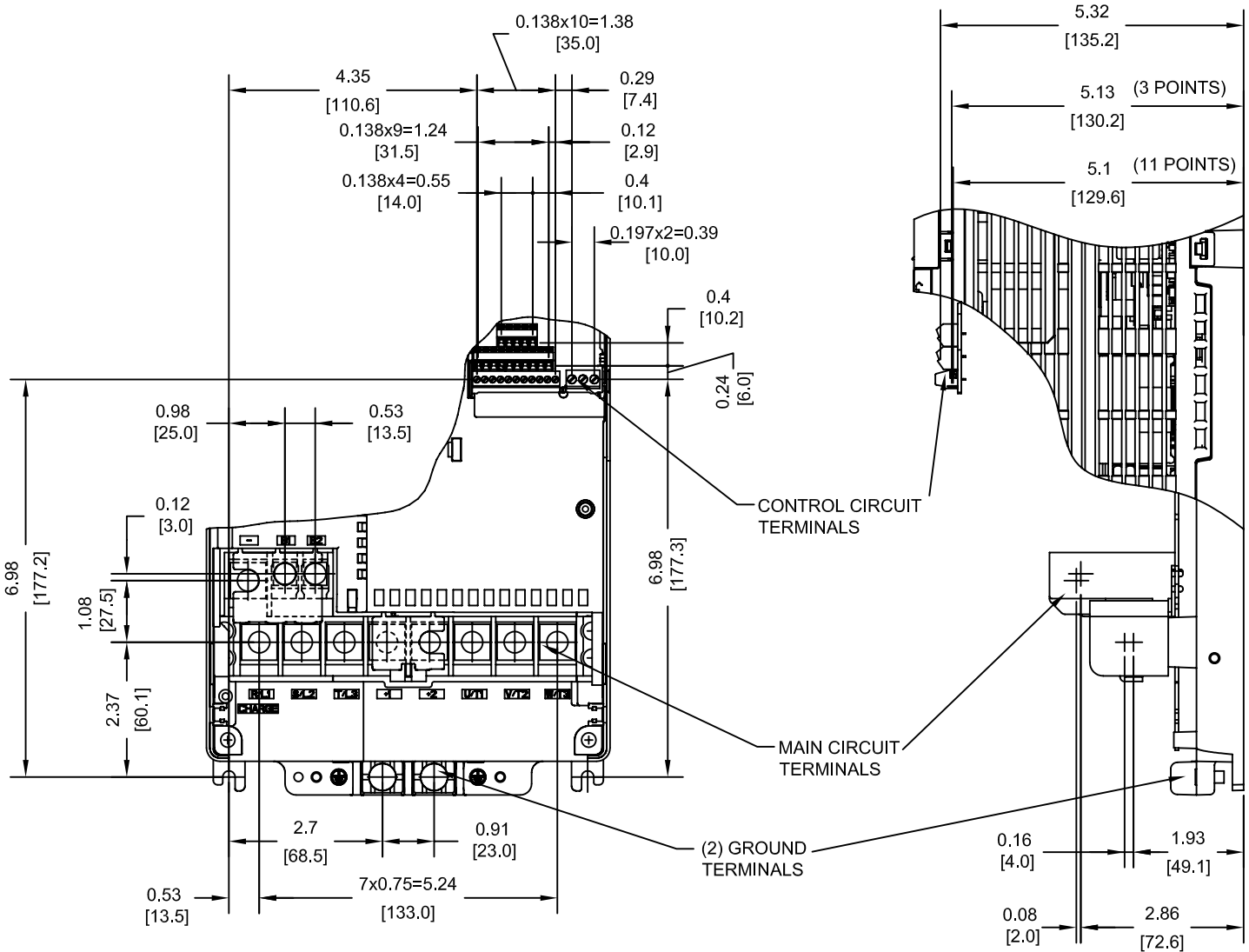

TERMINAL AND WIRE SPECIFICATIONS FOR MAIN CIRCUIT AND GROUND

MODEL # CIMR-VU	TERMINAL SYMBOL	TERMINAL SCREW	CLAMPING TORQUE lb.in.(N.m.)	WIRE RANGE AWG(mm ²)
2A0056J	R/L1, S/L2, T/L3, ⊙, ⊕1, ⊕2, U/T1, V/T2, W/T3	M6	35.4 TO 53.1 (4 TO 6)	6-4 (14-22)
	B1, B2	M5	17.7 TO 22.1 (2 TO 2.5)	10-6 (5.5-14)
	⊕	M6	35.4 TO 53.1 (4 TO 6)	6-4 (14-22)
4A0031J	R/L1, S/L2, T/L3, ⊙, ⊕1, ⊕2, U/T1, V/T2, W/T3, B1, B2	M5	17.7 TO 22.1 (2 TO 2.5)	10-6 (5.5-14)
	⊕	M6	35.4 TO 53.1 (4 TO 6)	10-6 (5.5-14)
4A0038J	R/L1, S/L2, T/L3, ⊙, ⊕1, ⊕2, U/T1, V/T2, W/T3, B1, B2	M5	17.7 TO 22.1 (2 TO 2.5)	10-6 (5.5-14)
	⊕	M6	35.4 TO 53.1 (4 TO 6)	10-6 (5.5-14)

NOTE: RATINGS APPLY TO BOTH FACTORY AND FIELD WIRING
 REFER TO APPLICABLE CODES FOR PROPER WIRE TYPE AND SIZE

FOR ADDITIONAL DETAILS AND SPECIFICATIONS, CONSULT MANUAL

TOLERANCES / REFERENCES:			DRAWN: J. MATTAS DATE: 1-8-09	TITLE: V1000 DIMENSION DRAWING FRAME SIZE 10 FINLESS HEATSINK 2A0056J, 4A0031J AND 4A0038J
UNITS: IN [mm]			CHECKED: J. PIOTROWSKI DATE: 4-27-09	DATE: 1-8-09
SCALE: BY VIEW		TECH: J. CAIRO DATE: 7-7-09	DATE: 7-8-09	SIZE: A
		APPROVED: T. SASADA DATE: 7-8-09	DATE: 7-8-09	REVISION: R00
		ORIGINAL DESIGN: -	DATE: -	PAGE: 2 of 3
		DRAWING #: DD.V1K.FR10.FNL.01		

MINIMUM INSTALLATION CLEARANCES (SCALE 1:5)

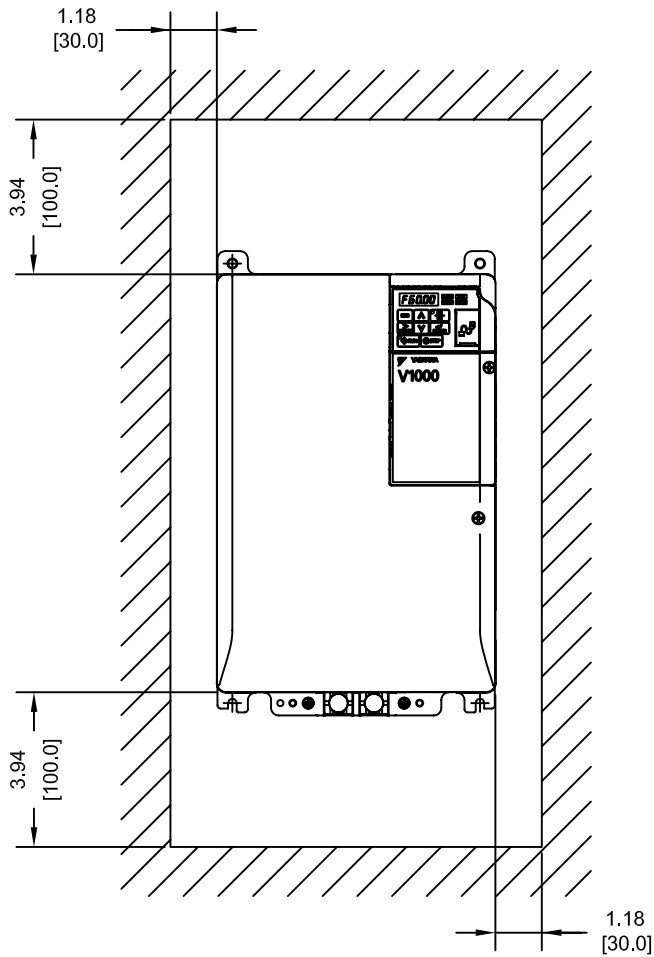

MOUNTING DIMENSIONS (SCALE 1:4)

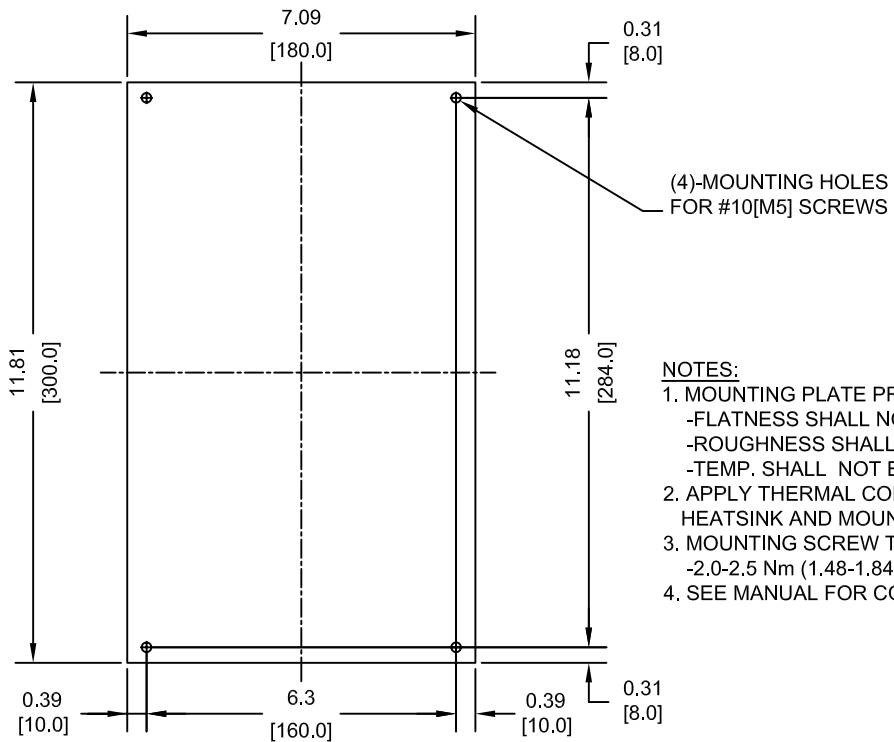

NOTES:

1. MOUNTING PLATE PROPERTIES
 - FLATNESS SHALL NOT EXCEED 0.2mm
 - ROUGHNESS SHALL NOT EXCEED 25S
 - TEMP. SHALL NOT EXCEED 90C (194F)
2. APPLY THERMAL COMPOUND BETWEEN HEATSINK AND MOUNTING PLATE.
3. MOUNTING SCREW TORQUE
 - 2.0-2.5 Nm (1.48-1.84 ft-lbf)
4. SEE MANUAL FOR COMPLETE DETAILS

TOLERANCES / REFERENCES:		<p>YASKAWA The Drive for Quality™</p> <p><i>THIS DOCUMENT AND INFORMATION CONTAINED IN IT ARE CONFIDENTIAL, AND CANNOT BE COPIED OR DISCLOSED IN WHOLE OR IN PART WITHOUT THE EXPRESS WRITTEN CONSENT OF YASKAWA ELECTRIC AMERICA INC.</i></p>	DRAWN: J. MATTAS DATE: 1-8-09	DATE: 1-8-09	TITLE: V1000 DIMENSION DRAWING FRAME SIZE 10 FINLESS HEATSINK 2A0056J, 4A0031J AND 4A0038J
			CHECKED: J. PIOTROWSKI DATE: 4-27-09	DATE: 4-27-09	
			TECH: J. CAIRO DATE: 7-7-09	DATE: 7-7-09	
			APPROVED: T. SASADA DATE: 7-8-09	DATE: 7-8-09	
UNITS: IN[mm]	SCALE: BY VIEW	ORIGINAL DESIGN: -			SIZE: A REVISION: R00 PAGE: 3 of 3
					DRAWING #: DD.V1K.FR10.FNL.01